

NEW INSTRUMENTATION FOR MEASUREMENT OF PRECIPITATION AT SEA*

L. Hasse, M. Grossklaus, H.-J. Isemer, and K. Uhlig

Institut für Meereskunde, Kiel, Germany

1. Introduction

Determination of precipitation at sea is an important part of the WCRP and GAW. Both, numerical models and satellite remote sensing methods can be used to estimate global coverage of precipitation at sea. However, with advanced methods, ground truth from sea is wanted more urgently. Also, for the GAW, reliable measurements of precipitation at sea are required. Atmospheric chemists have been very successful in measuring the concentration of admixtures in rain water. In order to calculate the flux of admixtures from the atmosphere to the ocean, both, the concentration in rain water and the amount of rain need to be known. There are more than 7000 Voluntary Observing Ships. Typically each day 2000 to 3000 ships collect meteorological data 8 times per day. If only a fraction of these would measure rain, we would have a sizable and welcome amount of information on precipitation at sea.

Unfortunately, conventional rain collecting instruments fail when used at buoys or ships (Olbrück, 5). While difficulties from platform motions to quantify collected water amount can be overcome by suitable gauging devices, the flow distortion problem remains. This problem stems from the rather high flow velocities around rain gauges at ships, that may result from addition of wind and ship velocities. This yields to two sources of biases:

- (i) The flow around the ship or buoy superstructure may induce spurious vertical velocities at the location of equipment, leading to under- or overcatch.
- (ii) The flow around the raingauge for most conventional types of raingauges tends to carry the rain above the orifice of the gauge, leading to a wind speed dependent undercatch.

Of these two sources of error it is hoped that the first one may perhaps be easier to deal with (Austin and Geotis, 1). The detrimental effect of flow distortion from the ships superstructure could be alleviated somewhat by suitable siting of the instrument, say above the flying bridge, where the flow might be expected to be horizontal. Also, the measurement technique itself could make the instrument less susceptible to local up- or downdrafts. At the same time, the instrument design must minimize velocity dependent errors of the instrument itself (Sevruk, 6; Folland 2).

In the marine meteorological department of Institut für Meereskunde, Kiel, we have therefore started to develop ship raingauges of improved design. Two types, based on a mechanical and an optical measurement technique, have been constructed. We will report on these instruments in the following.

2. Mechanical ship raingauge

The high relative flow velocities at a cruising ship in a wind field at sea may carry the rain almost horizontally over the ship. Hence, in our design, the conventional horizontal orifice of a raingauge has been supplemented by a cylindrical vertical collecting surface. Additionally, the local flow velocity is measured by a cup anemometer. A sketch of the instrument is given in figure 1. The water amount from both surfaces is collected separately, and measured by

*In: Instruments and observing methods, Report No. 49.
World Meteorological Organisation, Geneva (1992).
WMO/TD - No. 462, pp 195 - 198.

forming and counting drops of calibrated size. Other types of recording, that are insensitive to ship motions, would be acceptable also. Note that the shape of the instrument resembles the "champagne glass" configuration suggested by Folland (2) in order to reduce the undercatch resulting from flow distortion by the gauge itself. The horizontal orifice would measure rainfall like any landbased conventional raingauge. The vertical collecting surface measures liquid water content in the volume of air defined from the cross-section of the gauge and the local relative windspeed. From the liquid water content of the air, the rainfall rate can be estimated by assuming a Marshall-Palmer (4) raindrop size distribution. From the informations of the two collecting surfaces, considering local flow velocity, an empirical calibration of the instrument is feasible.

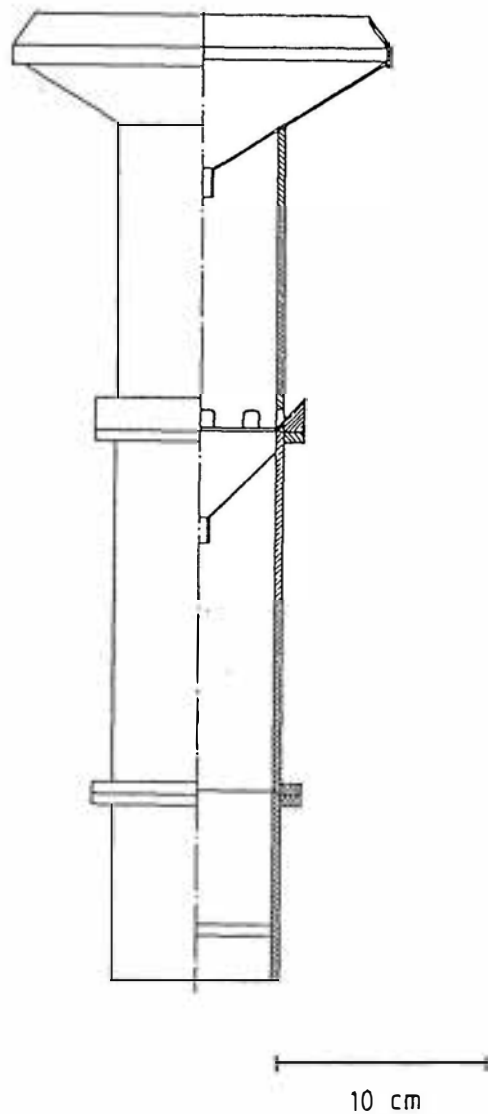

Figure 1: Sketch of mechanical raingauge. Left half is the view from the side, right half shows the cut. The instrument has a cylindrical cross section (80 mm diameter). The horizontal orifice at the top is taken from a standard weather service type Hellmann raingauge of 200 cm² size. The vertical collecting surface consists essentially of the cylinder (125 mm height) above the rime. The water amount intercepted by both surfaces is collected each by a cone and fed to a gauging unit in the lower part (not shown here). Counts are recorded either with a PC or with a data logging unit.

The instrument has been tested against a disdrometer during a research cruise and now undergoes a long term field trial at R.V. METEOR. In order to deal with ship roll motions in a seastate, the instrument is suspended to swing freely around an axis parallel to the ship's long axis. Collecting at the vertical surface will be rather insensitive to up- or down-drafts. The catch by the horizontal orifice, on the other hand, will be influenced by local up/or downdrafts, depending on the drop-size distribution. This requires to place the instrument high up above the superstructure of the ship in order to minimize influence of local ship induced vertical velocities.

3. Optical disdrometer

Preliminary tests with an optical rain indicating device (manufactured by Rudolph Logic Systems, 3202 Sarstedt, Germany) showed that it is feasible to measure individual raindrops and record these on a standard PC (compatible AT).

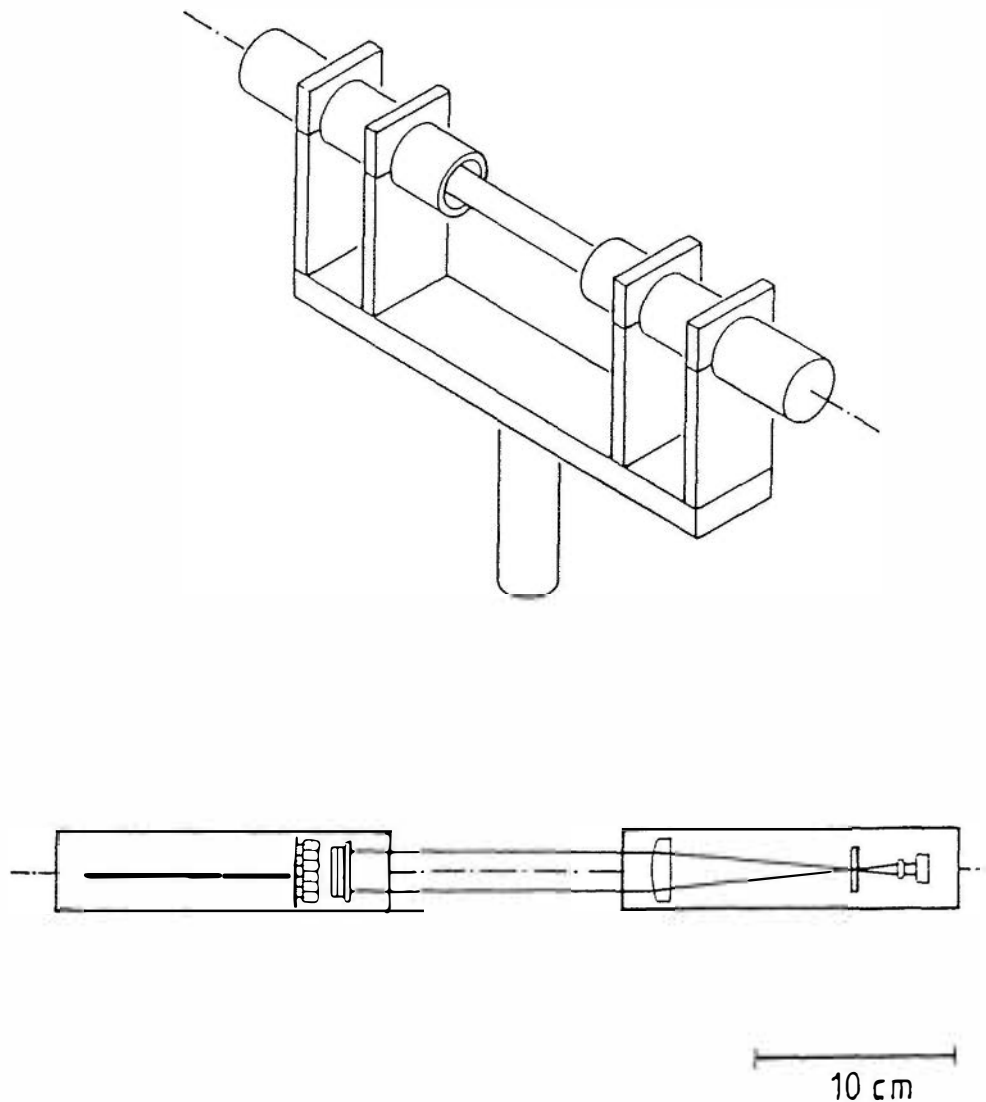

Figure 2: Optical disdrometer. Slant view (top) and vertical cross section (bottom). The instrument consists of (from left to right): electronics unit and light shoper, field of light emitting IR diodes, diffusor plates, window, sampling volume, collecting lens, baffle, collecting lens, photo detector, and amplifier.

The basic idea is to measure the size of a raindrop from its light extinction, obtain a dropsize spectrum and calculate the contribution to the rain rate for each drop, assuming that it will have the terminal velocity as determined from its diameter. The disdrometer essentially measures the probability of drops of given size per volume, that is needed to calculate the rain rate. This type of measurement was employed by Illingworth and Stevens (3).

However, their instrument is fairly sophisticated and the evaluation to obtain a rain rate is difficult. In order to have a design that could be used on VOS, we prefer a slightly different technique. Our optical disdrometer is depicted in figure 2. The sampling volume consists of a cylinder of infrared light of about 120 mm length and 21 mm diameter. The cylinder is kept perpendicular to the local flow direction by a wind vane. Because of the circular cross-section of the cylinder, the geometry for a transsecting drop is independent of its vertical component. Hence, vertical velocities induced from flow distortion by the ship's superstructure will not falsify the measurements. Care has been taken to ensure homogeneity of light in the sampling volume and to eliminate sensitivity to background illumination. At present the prototype #2 of the instrument is subjected to renewed field trials.

References

1. Austin, P.M. and G. Geotis, 1980: Precipitation measurements over the ocean. In: Dobson, Hasse, Davis (Ed.) "Air Sea Interaction - instruments and methods", Plenum Press, New York, 523 - 541.
2. Folland, C.K., 1988: Numerical models of the raingauge exposure problem, field experiments and an improved collector design. Q.J.R.Meteorol.Soc. 114, 1485 - 1516.
3. Illingworth, A.J. and C.J. Stevens, 1987: An optical disdrometer for the measurement of raindrop size spectra in windy conditions. J. Atm. Oc. Techn. 4, 411 - 421.
4. Marshall, J.S. and W.M. Palmer, 1948: The distribution of raindrops with size. J. Meteorol. 5, 165 - 166.
5. Olbrück, G., 1979: Precipitation measurements at sea. WMO, Marine Meteorological and Related Oceanographic Activities, Rep. No. 1, 39 pp.
6. Sevruk, B., 1989: Precipitation measurement. WMO/IAHS/ETH Workshop on precipitation measurement, St. Moritz, Dec. 1989. ETH Zürich, 584 pp.